

Installation/Installation/Instalación

Aerro

4" Centerset Lavatory Faucet

Robinet de lavabo monopièce, entraxe de 4 po

Grifo para lavabo, 4" de centro a centro



Tools You Will Need / Outils dont vous aurez besoin / Herramientas necesarias



Adjustable Wrench

Clé à molette

Llave ajustable



Pipe Tape

Ruban pour tuyau

Cinta selladora para rosca



Groove join pliers

Pince multiprise

Pinzas ajustables



Phillips Screwdriver

Tournevis cruciforme

Destornillador cruciforme



Silicone Sealant

Enduit d'étanchéité au silicone

Sellador de silicona

SAFETY TIPS

- If you use soldering for the installation of the faucet, the seats, cartridges and washers will have to be removed before using flame. Otherwise, warranty will be void on those parts.
- Cover your drain to avoid losing parts.

CONSIGNES DE SÉCURITÉ

- Si vous posez le robinet par brasage, il est essentiel de retirer les sièges, les cartouches et les rondelles avant d'appliquer la flamme, faute de quoi la garantie sur ces pièces sera annulée.
- Couvrez le drain pour ne pas perdre des pièces.

CONSEJOS DE SEGURIDAD

- En el caso de utilizar soldadura para instalar el grifo, remueva los asientos, cartuchos y arandelas antes de usar la llama. De lo contrario, se anulará la garantía para esos componentes.
- Tape la boca del desagüe para prevenir la pérdida de piezas pequeñas.

Installation/Installation/Instalación

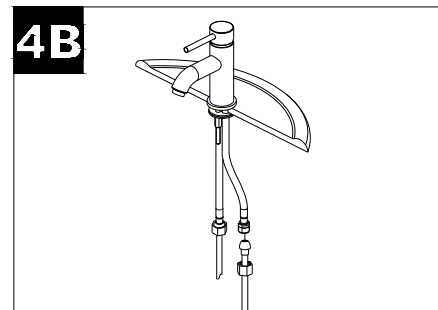
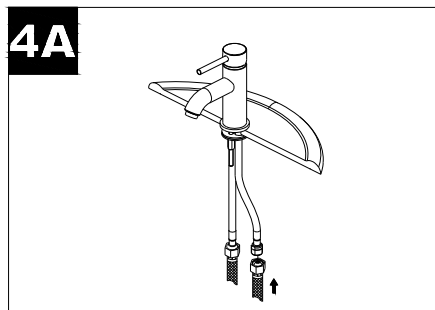
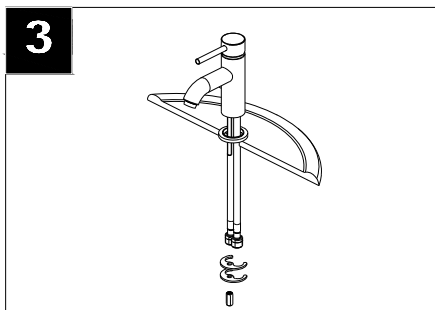
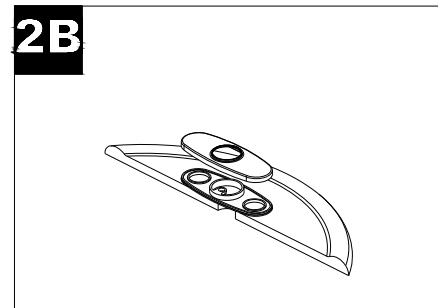
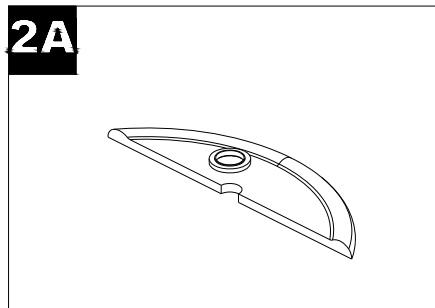
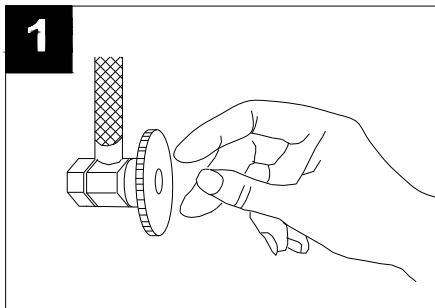

Trouble-Shooting / Dépannage / Guía de solucionar problemas

If you've followed the instructions carefully and your faucet still does not work properly, take these corrective steps.

Si vous avez suivi attentivement les instructions et que votre robinet ne fonctionne toujours pas correctement, apporter les correctifs suivants.

Si usted ha seguido las instrucciones cuidadosamente y su grifo todavía no funciona correctamente, siga estos pasos correctivos.

Problem/Problème/Problema	Cause/Cause/Causa	Action/Correctif/Solución
Leaks underneath handle.	Retainer nut has come loose. O-ring is dirty or damaged.	Tighten the retainer nut. Clean or replace O-ring.
Fuites sous la manette.	L'écrou de fixation s'est desserré. Le joint torique est sale ou endommagé.	Serrer l'écrou de fixation. Nettoyer ou remplacer le joint torique.
Goteo debajo de la manija.	La tuerca de ajuste se ha aflojado. La arandela circular está sucia o dañada.	Apriete la tuerca de ajuste. Limpie o reemplace la arandela circular.
Aerator leaks or has an inconsistent water flow pattern.	Aerator is dirty or misfitted.	Unscrew the aerator to check rubber packing or replace the aerator.
Le brise-jet fuit ou la diffusion des jets qui s'en écoulent n'est pas uniforme.	Le brise-jet est mal ajusté ou sale.	Dévisser le brise-jet pour vérifier le joint en caoutchouc. Résembler le brise-jet.
El aireador gotea o el chorro de agua está irregular.	El Aireador está sucio o mal puesto.	Destornille el aireador para chequear el empaque de caucho. Vuelva a instalar el aireador.

Pop-Up Drain Installation/Installation de la vidange mécanique/Instalación del desague levadizo

