

Installation/Installation/Instalación

3 Hole Roman Tub Rough-In Valve

Robinetterie brute de baignoire romaine, 3 orifices

Válvula interior para bañera tipo Romana de 3 agujeros



Tools You Will Need / Outils dont vous aurez besoin / Herramientas necesarias



Adjustable Wrench

Clé à molette

Llave ajustable



Pipe Tape

Ruban pour tuyau

Cinta selladora para rosca



Groove join pliers

Pince multiprise

Pinzas ajustables



Phillips Screwdriver

Tournevis Phillips

Destornillador cruciforme

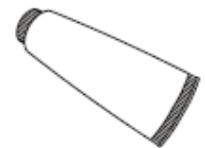

Silicone Sealant

Enduit d'étanchéité au silicone

Sellador de silicona

SAFETY TIPS

- If you use soldering for the installation of the faucet, the seats, cartridges and washers will have to be removed before using flame. Otherwise, warranty will be void on those parts.
- Cover your drain to avoid losing parts.

CONSIGNES DE SÉCURITÉ

- Si vous posez le robinet par brasage, il est essentiel de retirer les sièges, les cartouches et les rondelles avant d'appliquer la flamme, faute de quoi la garantie sur ces pièces sera annulée.
- Couvrir le drain pour ne pas perdre des pièces.

CONSEJOS DE SEGURIDAD

- En el caso de utilizar soldadura para instalar el grifo, remueva los asientos, cartuchos y arandelas antes de usar la llama. De lo contrario, se anulará la garantía para esos componentes.
- Tape la boca del desagüe para prevenir la pérdida de piezas pequeñas.

Installation/Installation/Instalación

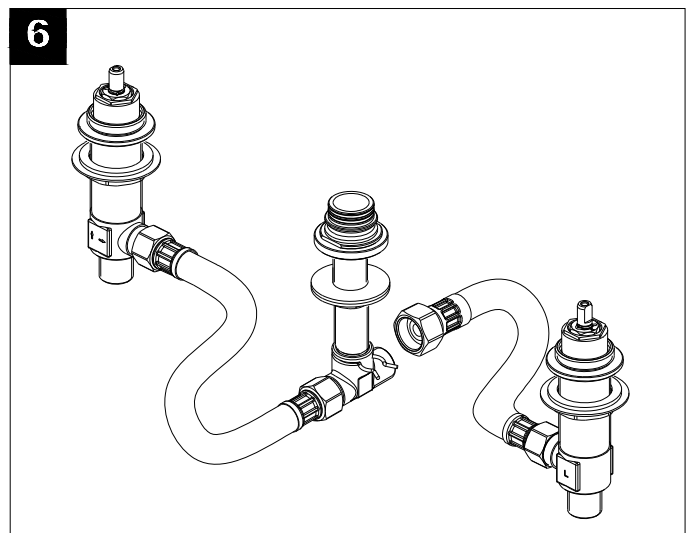
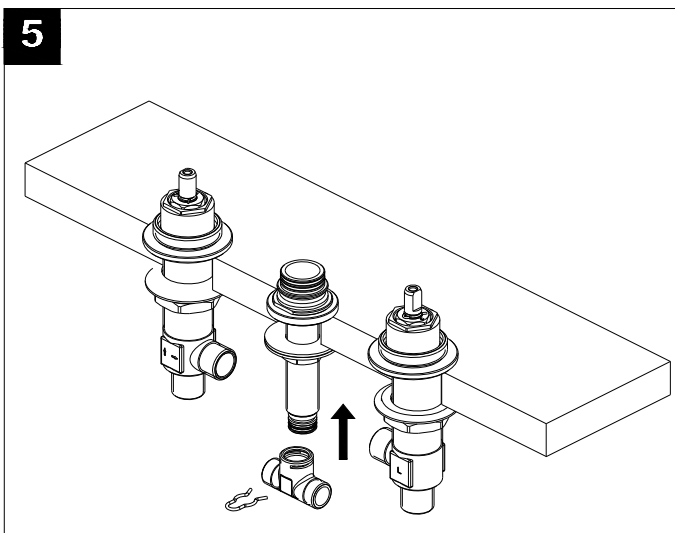
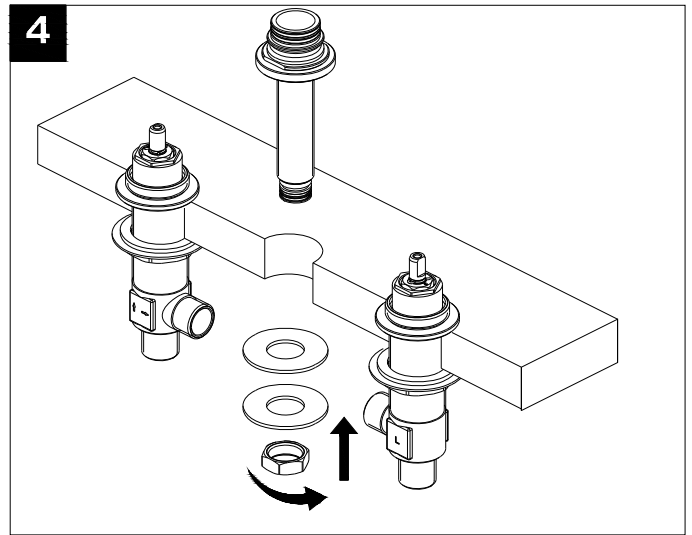
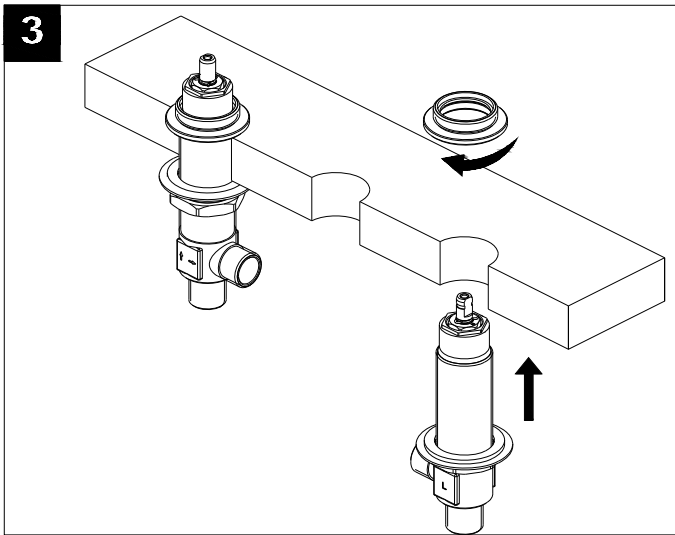
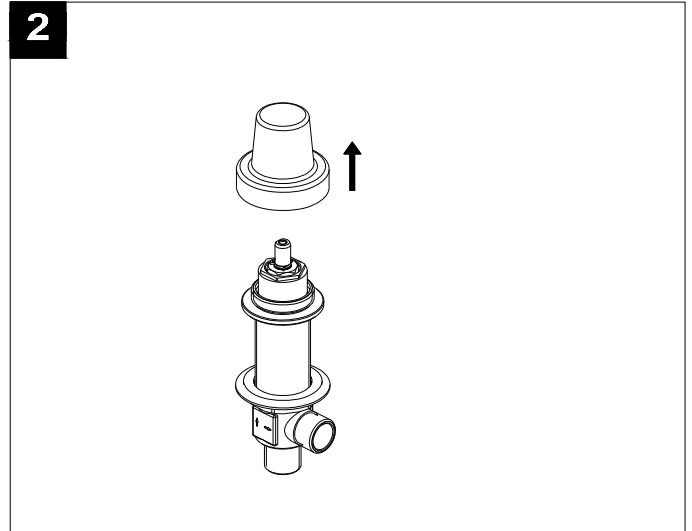
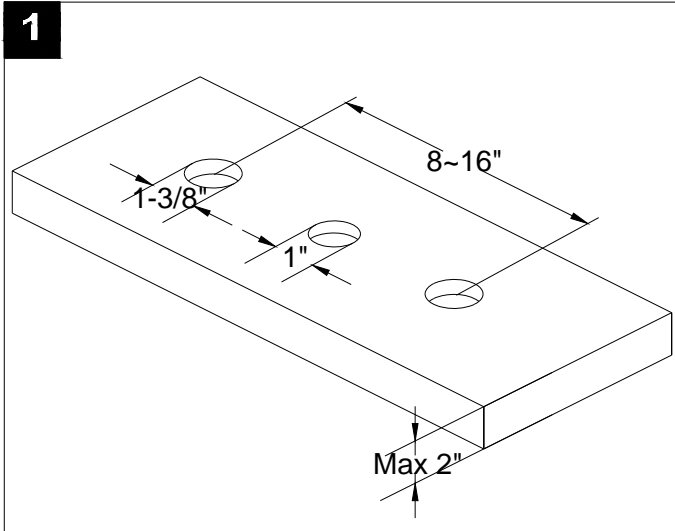

Replacement Parts / Pièces de rechange / Repuestos

No.	Description	Part No.
1	Nut/ Écrou/ Tuerca	RP70001
2	Flange & Washer/ Bride et rondelle/ Brida y arandela	RP70183
3	Hot Cartridge/ Cartouche pour eau chaude/ Cartucho-agua caliente	RP20013
	Cold Cartridge/ Cartouche pour eau froide/ Cartucho-agua fría	RP20014
4	Washer/ Rondelle/ Arandela	RP64023
5	Metal Washer/ Rondelle métallique/ Arandela de metal	RP64024
6	Mounting Nut/ Écrou de fixation/ Tuerca de montaje	RP56014
7	Body/ Corps/ Cuerpo	RP70039
8	Coupling Nut/ Écrou de raccordement/ Tuerca de unión	RP56002
9	Hose/ Tuyau/ Manguera	RP70042
10	O-Ring / Joint torique/ Empaque circular	RP60056
11	Flange & Washer/ Bride et rondelle/ Brida y arandela	RP80152
12	Washer/ Rondelle/ Arandela	RP64032
13	Metal Washer/ Rondelle métallique/ Arandela de metal	RP64033
14	Nut/ Écrou/ Tuerca	RP56015
15	Clip/ Collier/ Abrazadera	RP70123
16	O-Ring / Joint torique/ Empaque circular	RP60047
17	T-tube/ Tube en T/ Tubo angular	RP70124

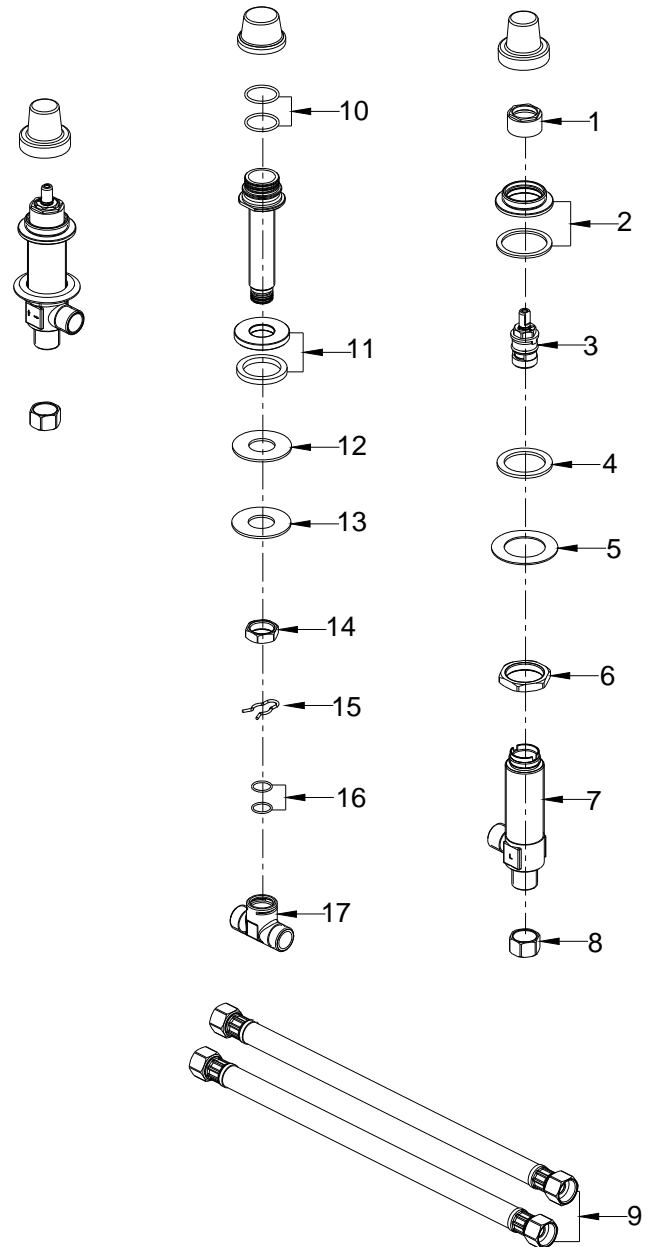

Need Help? Please call our toll-free customer service line at **1-770-205-8792** for additional assistance or service.

Besoin d'aide? Veuillez communiquer avec notre service à la clientèle au numéro gratuit **1-770-205-8792** pour tous renseignements ou services complémentaires.

¿Requiere asistencia? Llame a nuestro Servicio al Cliente, sin costo, al **1-770-205-8792** para asistencia adicional o servicio.